



RUSSIAN FEDERATION
MINISTRY OF TRANSPORT OF THE RUSSIAN FEDERATION
FEDERAL AIR TRANSPORT AGENCY
AIRWORTHINESS DIRECTIVE

23 November, 2023

No. 2023-AHCAT,AHCAT-CK-06

Applicability – ANSAT helicopters (ANSAT, ANSAT-GC model)

Designer's State - RUSSIAN FEDERATION

Corrective actions stated in the present Airworthiness Directive are mandatory. None of the operators is allowed to operate the aircraft covered by present Airworthiness Directive otherwise than according to the requirements of present Directive.

On September 5, 2023 during the flight of the ANSAT helicopter No. 070A01 the fire detector has been actuated in the RH engine undercowling compartment. According to the results of investigation it was determined that during the flight, while performing the main rotor autorotation, the right engine was shut down due to a faulty engine power selector switch set to IDLE position, which led to an increase in temperature in the undercowling compartment due to the lack of air ejection from the gas generator compartment and ignition of the paint coating applied on the inside of the rear cowling panel 334.6930.200-01, which was not provided in the design documentation.

In addition, during the helicopter inspection the presence of ЦИАТИМ-201 grease was detected on hinges 333.6930.020-01 (-02), 333.6930.030-01 (-02) of rear cowling panels 334.6930.200-01 (-02), which was not provided in the design and operational documentation, and which, under the influence of elevated temperatures, was an additional source of ignition.

Based on the Technical decision of JSC "Kazan Helicopters" No. 3/144-2023-KB3 dated 31.20.2023 (Technical decision) in order to ensure the flight safety and airworthiness of the civil aviation ANSAT helicopters fleet

THE FOLLOWING IS PROPOSED:

On the ANSAT helicopters (ANSAT, ANSAT-GC models) since the entry into force of present Airworthiness directive:

1. Operators of the ANSAT helicopters (ANSAT-GC model) shall perform the works in accordance with the paragraphs 1 and 2 of Technical decision, when carrying out periodic technical maintenance within the scope of "50 flight hours // 12 calendar months" maintenance form.

2. Operators shall inform JSC "Kazan Helicopters" and Federal Air Transport Agency (FATA) about results of works completion in accordance with p. 1 of this Airworthiness directive.

3. Airworthiness directive comes into force on November 27, 2023 and becomes invalid upon full compliance with all its requirements followed by continued operation of the helicopter in accordance with the effective operational documentation.

Appendix: Technical decision No. 3/144-2023-KB3, 5 sheets.

Deputy Director General of FATA

П. П.

V.V. Poteshkin



Верно:

[Handwritten signature]
29.01.2024

[Handwritten signature]

APPROVED
Deputy managing director –
Head of Design
JSC “Kazan Helicopters”

A.O. Garipov
№ 41749-144-УкхП
07.12.2023.

TECHNICAL DECISION No.3/144-2023-KB3
on continued airworthiness of ANSAT helicopters (ANSAT, ANSAT-GC models)

On September 5, 2023 during the flight of the ANSAT helicopter No. 070A01 the fire detector has been actuated in the RH engine undercowling compartment. According to the results of investigation it was determined that during the flight, while performing the main rotor autorotation, the right engine was shut down due to a faulty engine power selector switch set to IDLE position, which led to an increase in temperature in the undercowling compartment due to the lack of air ejection from the gas generator compartment and ignition of the paint coating applied on the inside of the rear cowling panel 334.6930.200-01, which was not provided in the design documentation.

In addition, during the helicopter inspection the presence of ЦИАТИМ-201 grease was detected on hinges 333.6930.020-01 (-02), 333.6930.030-01 (-02) of rear cowling panels 334.6930.200-01 (-02), which was not provided in the design and operational documentation, and which, under the influence of elevated temperatures, was an additional source of ignition.

In order to ensure the airworthiness of the ANSAT helicopters (ANSAT, ANSAT-GC models) being in operation, the following decision was made.

DECISION:

On the ANSAT helicopters (ANSAT, ANSAT-GC models) since the issue of present Technical Decision:

1. When carrying out periodic technical maintenance within the scope of "50 flight hours // 12 calendar months" maintenance form, inspect the inside of the rear cowling panels 334.6930.200-01 (-02) (pos. 1, 2, Fig. 1, Appendix 1), the inside of the gas generator compartment covers 334.6931.500-01 (-02) (pos. 3, 4, Fig. 1, Appendix 1), the hinges 333.6930.020-01 (-02) and 333.6930.030-01 (-02) (pos. 5, 6, 7, 8, Fig. 1, Appendix 1) for presence of paint coating, as well as for presence of ЦИАТИМ-201 grease in the area of the hinges connection to the brackets of the rear cowling panels.

In case of detection of paint coating, perform its removal in accordance with the temporary task card 071.10.00e (Appendix 2).

In case of detection of ЦИАТИМ-201 grease in the area of the hinges connection to the brackets of the rear cowling panels, remove it with НЕФРАС solvent, brush and cotton rag.

TECHNICAL DECISION No. 3/144-2023-KB3
on continued airworthiness of the ANSAT helicopters (ANSAT, ANSAT-GC models)

2. Works in accordance with p. 1 shall be carried out by the Operator.
3. Operators shall inform JSC “Kazan Helicopters” and Federal Air Transport Agency about results of works carried out in accordance with p. 1 of present Technical decision.
4. Operators shall follow the requirements of present Technical decision until its full implementation.

TECHNICAL DECISION No. 3/144-2023-KB3
 on continued airworthiness of the ANSAT helicopters (ANSAT, ANSAT-GC models)

APPENDIX 1

Position	Description	Designation
1	Rear cowling panel	334.6930.200-01
2	Rear cowling panel	334.6930.200-02
3	Gas generator compartment cover	334.6931.500-01
4	Gas generator compartment cover	334.6931.500-02
5	Hinge	333.6930.020-01
6	Hinge	333.6930.020-02
7	Hinge	333.6930.030-01
8	Hinge	333.6930.030-02
9	Installation of LH (RH) struts	333.6930.700-02(-01)

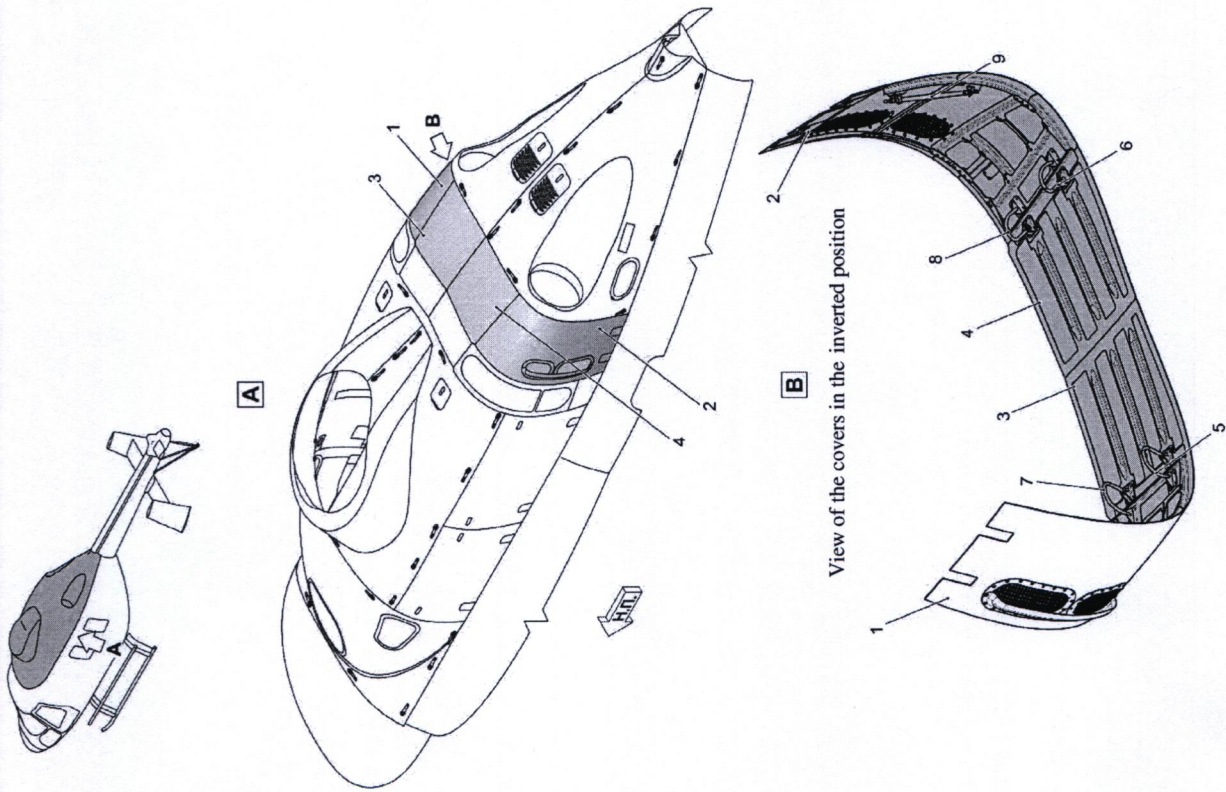

Fig. 1

TECHNICAL DECISION No. 3/144-2023-KB3
on continued airworthiness of the ANSAT helicopters (ANSAT, ANSAT-GC models)

APPENDIX 2

Temporary task card 071.10.00e	
Procedure: Removal of paint coating from the inside of gas generator compartment covers and rear cowling panels.	
Operations and technical requirements	Corrective actions
<p>1 Remove covers of gas generator compartment and rear cowling panels:</p> <p>1.1 Install the stepladder on the portside (starboard) in the area of frame No. 10.</p> <p>1.2 Use a screwdriver to unscrew the screws attaching the LH (RH) cover of the gas generator compartment.</p> <p>1.3 Open the cowling locks of the LH (RH) rear cowling panel.</p> <p>1.4 Remove the LH (RH) cover of the gas generator compartment, as well as the LH (RH) rear cowling panel.</p> <p>2 Sand the inner surface of the gas generator compartment covers 334.6931.500-01 (-02) to expose the metal surface, as well as the inner surface of rear cowling panels 334.6930.200-01 (-02) using sand paper P240, P320, P500, P600, gradually reducing the grit of the sand paper.</p> <p>CAUTION. DO NOT REMOVE PAINT COATING ON THE HINGES 333.6930.020-01 (-02), 333.6930.030-01 (-02) AND ON THE STRUTS 333.6930.700-01(-02).</p> <p>3 Remove the sanding products using cotton rags.</p> <p>Note – Instead of works according to paragraphs 2, 3, it is allowed to use the APS-A paint remover to remove the paintwork. The paint remover should be applied with brush in continuous uniform layer 0.5-1 mm thick. Allow some time for paint remover to stay on the surface until paint coating is cracked and loosened. After swelling of the paint coating, it is recommended to wait another 10-15 minutes. Softened paint coating should be removed using spatula, scraper, compressed air or jet of water using high-pressure setup. Repeat the application of paint remover if some residues of paint exist. Do not allow the paint remover to dry on the surface to be treated. After removing the paint coating, the surface should be rinsed with water (preferably warm), technical detergent or organic solvent of AJIT602/218 type.</p> <p>WARNING. WORK IN WELL-VENTILATED AREA WHEN USING APS-A PAINT REMOVER. WHEN CARRYING OUT WORKS, USE WORKWEAR AND PROTECTIVE EQUIPMENT: FOR RESPIRATORY ORGANS – RESPIRATORS, FOR EYES - SEALED GLASSES, FOR HANDS - PROTECTIVE GLOVES.</p> <p>4 Install the gas generator compartment covers and rear cowling panels:</p> <p>4.1 Install in its place the LH (RH) cover of the gas generator compartment and LH (RH) rear cowling panel.</p> <p>4.2 Close the cowling locks of the LH (RH) rear cowling panel.</p> <p>4.3 Use a screwdriver to tighten the screws attaching the LH (RH) cover of the gas generator compartment.</p> <p>4.4 Remove the stepladder.</p>	
Test equipment	Tools and appliances
	<p>Flat-slot screwdriver, Stepladder H=1400 mm 333.9917.100, Brush KΦ-60, Spatula, Scraper</p>
Expendable materials	
	<p>Sand paper (P240, P320, P500, P600), Cotton rag, paint remover APS-A, Solvent of AJIT602/218 type</p>