



RUSSIAN FEDERATION
MINISTRY OF TRANSPORT OF THE RUSSIAN FEDERATION
FEDERAL AIR TRANSPORT AGENCY
AIRWORTHINESS DIRECTIVE

19 of October, 2023

No. 2023-AHCAT-CK-04

Applicability – ANSAT helicopters (ANSAT-GC model)

Designer's State - RUSSIAN FEDERATION

Corrective actions stated in the present Airworthiness Directive are mandatory. None of the operators is allowed to operate the aircraft covered by present Airworthiness Directive otherwise than according to the requirements of present Directive.

The facts of the use of rubber plate ПН-2,0-3826C HTA TY 38 1051959.2-2020 with unconfirmed quality certificate (ref. No. 2549 dated 14.09.2023 JSC "RT-Techpriemka") were identified in JSC "Kazan Helicopters" production process of manufacturing rubber gaskets installed in the fuel system of the ANSAT helicopters. Due to the fact that the use of low-quality material could potentially lead to gaskets destruction into small fragments and clogging of the jet pumps of the fuel system and fuel filters of the PW207K engines, as well as in order to ensure the airworthiness of ANSAT helicopters being in operation, based on the Technical decision of JSC "Kazan Helicopters" No. 2/144-2023-KB3 dated 28.09.2023

PROPOSED:

1. During the next periodic technical maintenance of the ANSAT helicopters (ANSAT-GC model) Nos. 33154, 33155 within the scope of "50 flight hours // 12 calendar months" the operator shall perform works in accordance with the paragraph 1 of Technical decision No. 2/144-2023-KB3 dated 28.09.2023 (Technical decision).

2. When carrying out the works in accordance with the task card 028.10.00b "Fuel sediment drain from the tanks" within the frame of "Pre-flight preparation" of the ANSAT helicopters (ANSAT-GC model) Nos. 33149, 33150, 33152, 33153, 33156-33159 perform the analysis of fuel sediment for presence of any mechanical impurities and rubber particles (products of destruction of rubber gaskets).

In case of detection of products of destruction of rubber gaskets in the fuel sediment:

- a) temporarily suspend the operation of the helicopter;
- b) perform works in accordance with pp. 2.1-2.8 of Technical decision.

If there are no products of destruction of rubber gaskets in the fuel sediment, works according to paragraphs 2.1–2.8 of Technical decision should be performed during the next periodic maintenance form of "50 flight hours / 12 calendar months".

3. Upon completion of works according to p. 2 of Technical decision perform ground running and subsequent test flight with additional monitoring of fuel system and PW207K engines parameters in accordance with the helicopter Flight manual 343.0000.00 РЛЭ.

If the results of the test flight are positive, the operation of the helicopter should continue.

4. In case of detection of products of destruction of rubber gaskets during the analysis of fuel sediment according to paragraph 2 of Technical decision – it is necessary to establish the periodicity of inspection of fuel filters of PW207K engines for the absence of products of destruction of rubber gaskets – every 50 ± 5 flight hours within the next 200 flight hours (sealing rings MS9967-139, MS9967-212 of the PW207K engine filter element could be reused if there are no deviations detected during their visual inspection). If the products of destruction of rubber gaskets are detected on the fuel filters of engines, perform the works according to paragraphs 2.2-2.5, 2.7, 3 of Technical decision once again.

5. Execution of works according to the pp. 1, 2, 3, 4 shall be carried by the operator. Serviceability test of electric centrifugal pumps ЭЦН-73 and checking the pressure switches MCTB-0,3C for the purpose of confirmation of switch alarm point shall be carried out at the premises of JSC "Kazan Helicopters" in accordance with pp. 6 and 12 of temporary task card 028.10.00g (Appendix 2 of Technical decision). Rubber gaskets and washers for replacement according to the pp. 1, 2.6, 2.8 shall be provided by JSC "Kazan Helicopters" at its own expense.

6. Operators shall inform JSC "Kazan Helicopters" and Federal Air Transport Agency (FATA) about results of completion of works in accordance with paragraphs 1, 2, 3, 4 of present Airworthiness directive.

7. Airworthiness directive comes into force from the date of its issue. Operators shall follow the requirements of present Airworthiness directive until all requirements are fully met, with the subsequent continuation of helicopter operation in accordance with the effective operational documentation.

Appendix: Technical decision No. 2/144-2023-KB3, on 14 sheets;

Deputy Head of FATA

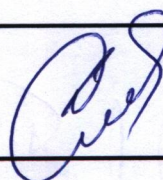

A.A. Dobryakov

APPROVED
Deputy managing director –
Head of Design
JSC “Kazan Helicopters”
A.O. Garipov

TECHNICAL DECISION No. 2/144-2023-KB3

on continued airworthiness of the ANSAT helicopters (ANSAT-GC model)

In connection with the identification of the fact of the use of rubber plate ПИH-2,0-3826C HTA TY 38 1051959.2-2020 with unconfirmed quality certificate (ref. No. 2549 dated 14.09.2023 JSC "RT-Techpriemka") in JSC "Kazan Helicopters" production process of manufacturing rubber gaskets installed in the fuel system of the ANSAT helicopters, which could potentially lead to the gaskets destruction into small fragments and clogging of the jet pumps of the fuel system and fuel filters of the PW207K engines, as well as in order to ensure the airworthiness of ANSAT helicopters being in operation, the following decision was made.

DECISION:

Since the issue of present technical decision:

1 When carrying out periodic maintenance of the ANSAT helicopters (ANSAT-GC model) Nos. 33154, 33155 within the scope of "50 flight hours / 12 calendar months" technical maintenance, replace the washer 334.6110.668 (see pos. 41 in Appendix 1) from the cover assembly 334.6110.660 (see pos. 5 in Appendix 1) in accordance with the temporary task card 028.10.00h (Appendix 2).

2 When carrying out the works in accordance with the task card 028.10.00b “Fuel sediment drain form the tanks” within the frame of “Pre-flight preparation” of the ANSAT helicopters (ANSAT-GC model) Nos. 33149, 33150, 33152, 33153, 33156-33159, perform the analysis of fuel sediment for presence of any mechanical impurities and rubber particles (products of destruction of rubber gaskets).

In case of detection of products of destruction of rubber gaskets in the fuel sediment:

- temporarily suspend the operation of the helicopter;
- perform works in accordance with pp. 2.1-2.8 of present Technical decision;

If there are no products of destruction of rubber gaskets in the fuel sediment, works according to the paragraphs 2.1–2.8 of present Technical decision should be performed during the next periodic maintenance form of "50 flight hours / 12 calendar months".

2.1 Inspect the fuel filters of the helicopter engines for presence of rubber particles - products of destruction of rubber gaskets (in accordance with “PW207K. Turboshaft engine. Maintenance manual No. 3053372»). When removing the filter element of PW207K engine it is allowed to reuse sealing rings (MS9967-139, MS9967-212) provided there are no deviations detected during their visual inspection.

2.2 In accordance with the pp. 1-5, 7-11, 13-15, 19-21, 26, 28 of task card 028.10.00c of the Maintenance manual 343.0000.00 PЭ perform removal of:

- pipelines, connecting fuel tanks Nos. 1 and 2 and service tanks;
- plates of fuel tanks Nos. 1 and 2;
- plates of service tanks;
- sleeves with fuel residue drain tap;
- drain fittings;

TECHNICAL DECISION No. 2/144-2023 –KB3
on continued airworthiness of ANSAT helicopters (ANSAT-GC model)

Additionally, remove the angle-pieces (see pos. 24-26 of Appendix 1) of the pipelines attachment to the fuel tank plates by unscrewing the mounting screws.

2.3 Inspect rubber gaskets installed on the fuel tanks (see Appendix 1) for presence of delamination, crumbling, cracks.

2.4 Inspect the internal cavities of all fuel tanks for presence of rubber particles (products of destruction of rubber gaskets).

2.5 In case of detection of delamination, crumbling and cracks of rubber gaskets, rubber particles, products of destruction of rubber gaskets in the internal cavities of fuel tanks and on the fuel filters of helicopter engines according to the results of inspections according to paragraphs 2.1, 2.3, 2.4 – perform works on fuel system cleaning according to the temporary task card 028.10.00g (Appendix 2).

2.6 Replace rubber gaskets (see pos. 7-16 in Appendix 1) with new ones.

2.7 Install the fuel system components removed according to the p. 2.2 in accordance with the task card 028.10.00d. Install the angle-pieces of the pipelines attachment to the fuel tank plates in place by screwing the mounting screws with a torque $M=4.4+0.5Nm$ ($0.45+0.05\text{ kgf}\cdot\text{m}$), lock the screws in accordance with p. 4.5 of OCT 1 39502-77 standard.

2.8 Replace the washer 334.6110.668 (see pos. 41 in Appendix 1) from cover assembly 334.6110.660 (see pos. 5 in Appendix 1) in accordance with temporary task card 028.10.00h (Appendix 2).

3 Upon completion of works according to p. 2 of present technical decision perform ground running and subsequent test flight with additional monitoring of fuel system and PW207K engines parameters in accordance with the helicopter Flight manual 343.0000.00 PJТЭ.

If the results of the test flight are positive, the operation of the helicopter should continue.

4 In case of detection of products of destruction of rubber gaskets during the analysis of fuel sediment according to paragraph 2 of this Technical decision – it is necessary to establish the periodicity of inspection of fuel filters of PW207K engines for the absence of products of destruction of rubber gaskets – every 50 ± 5 flight hours within the next 200 flight hours (sealing rings MS9967-139, MS9967-212 of the PW207K engine filter element could be reused if there are no deviations detected during their visual inspection). If the products of destruction of rubber gaskets are detected on the fuel filters of engines, perform the works according to paragraphs 2.2-2.5, 2.7, 3 of present Technical decision once again.

5 The works in accordance with paragraphs 1, 2, 3, 4 are to be carried out by the operator. Rubber gaskets and washers for replacement according to paragraphs 1, 2.6, 2.8 are to be provided by JSC “Kazan Helicopters” at its own expense.

6 Operators shall inform JSC “Kazan Helicopters” and Federal Air Transport Agency (FATA) about results of completion of works in accordance with paragraphs 1, 2, 3, 4 of present technical decision.

7 Operators shall follow the requirements of present technical decision until its full implementation, followed by continued operation of the helicopter in accordance with the effective operational documentation.

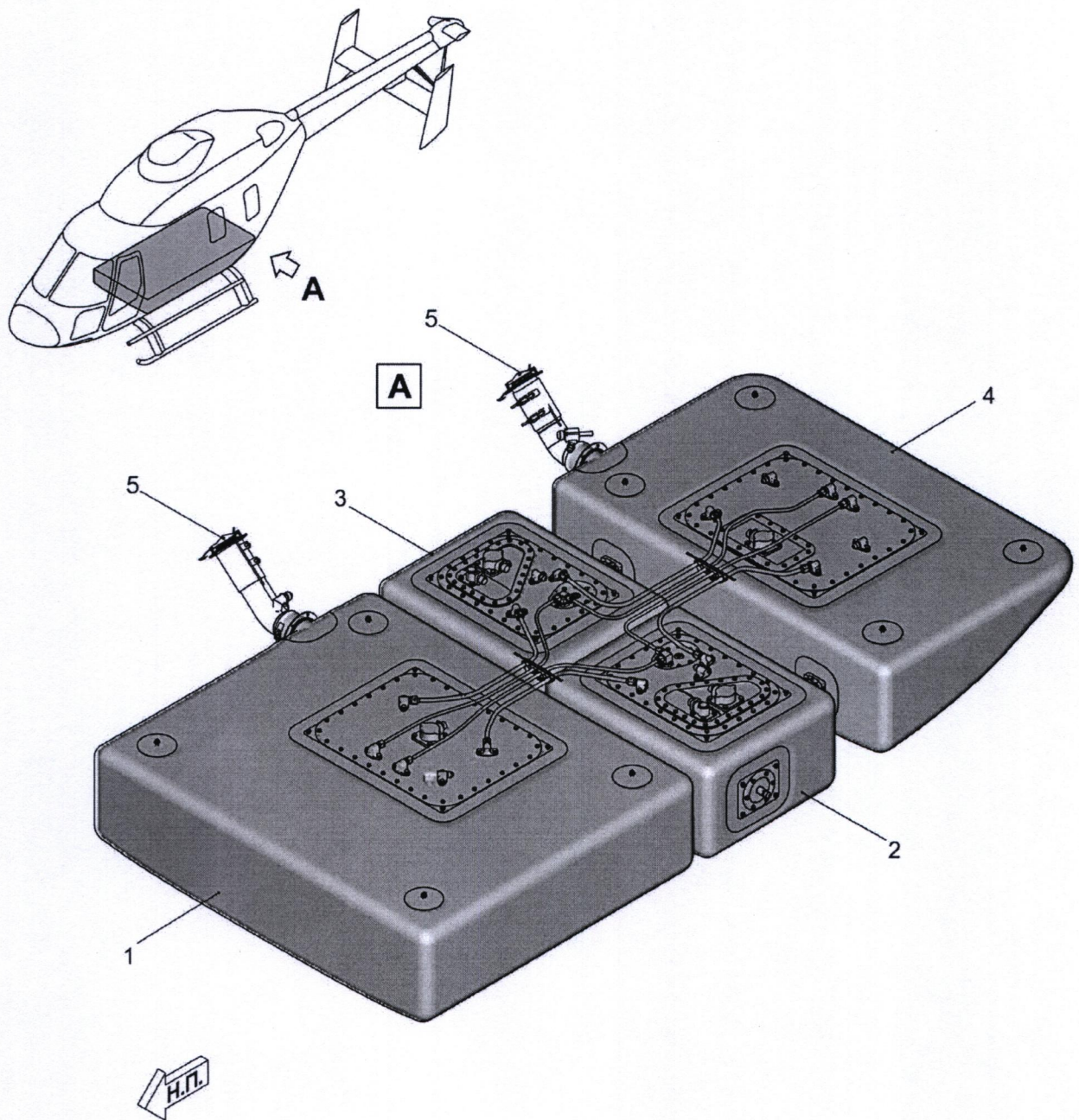

**Fig. 1 Fuel tanks installation
in the ANSAT helicopter (model ANSAT-GC)**

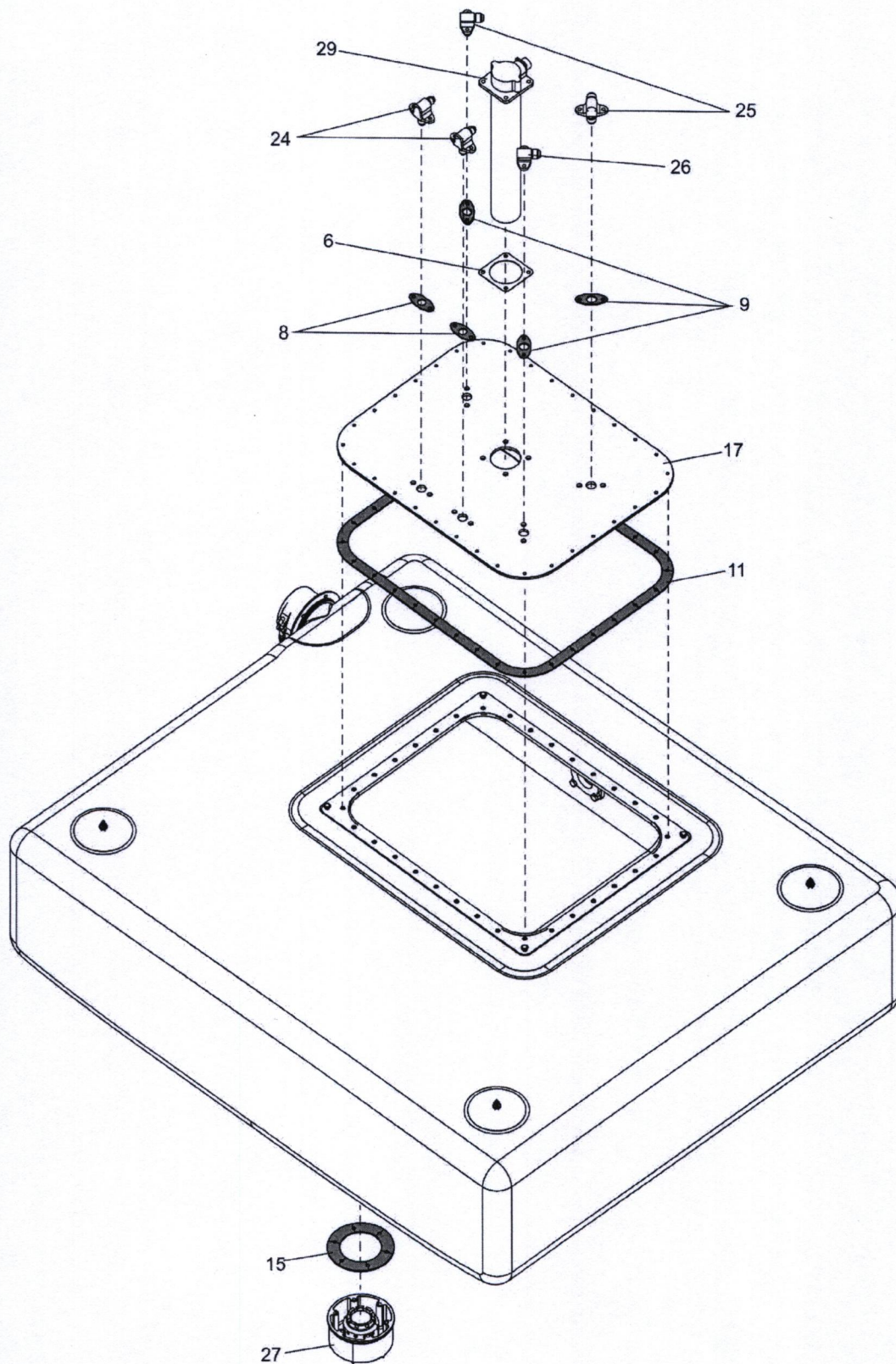

Fig. 2 Fuel tank No. 1

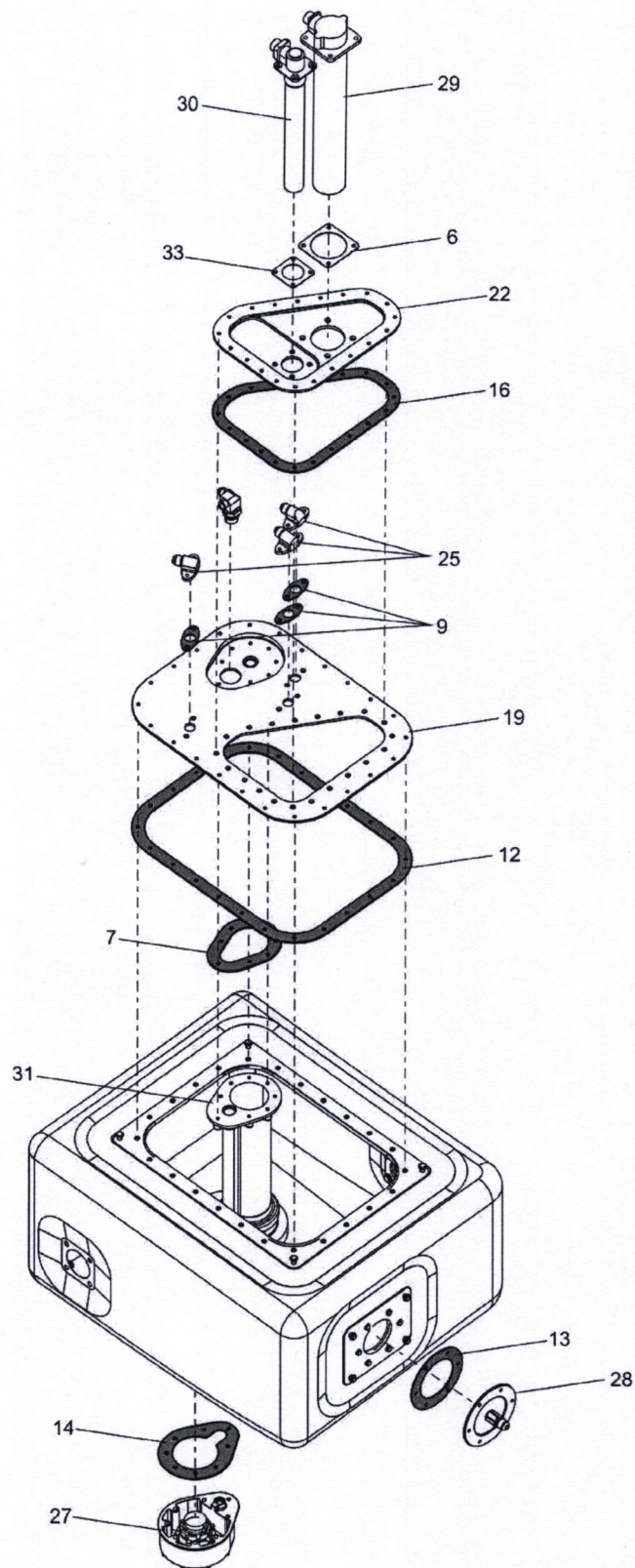

Fig. 3 Service tank (left)

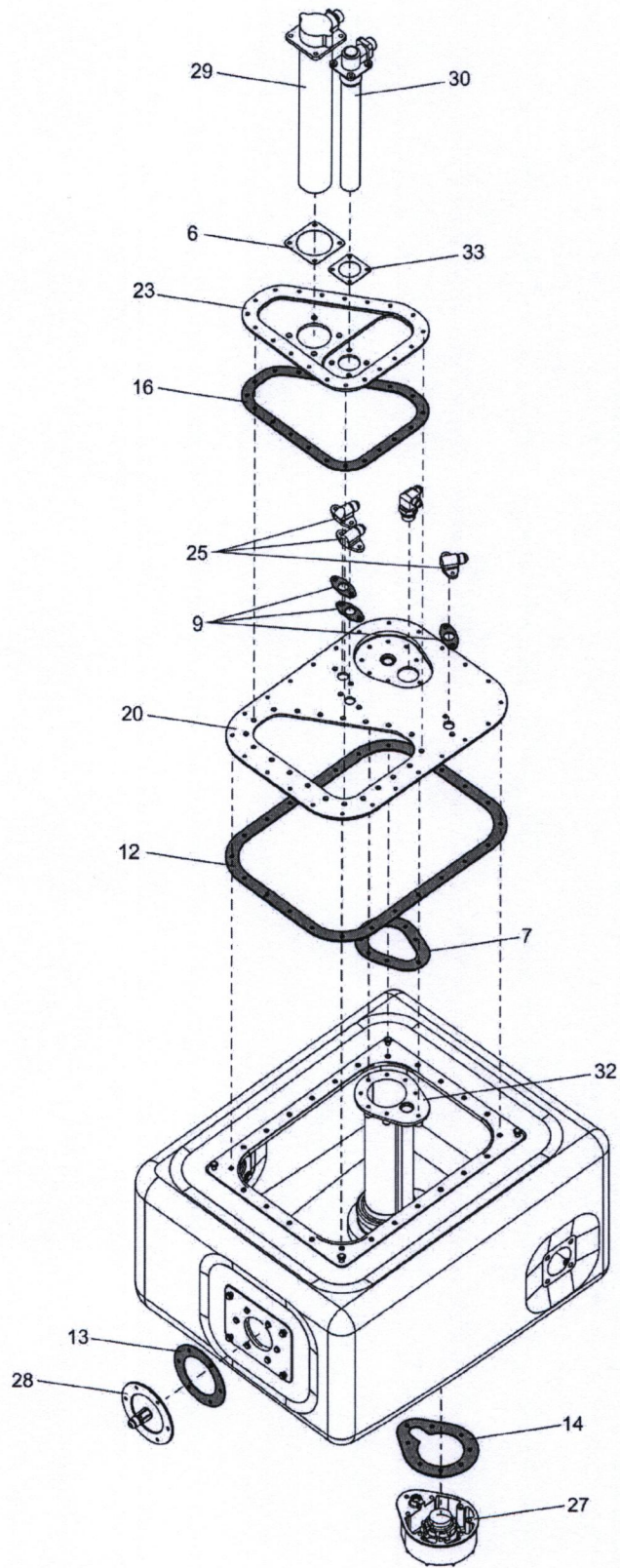

Fig. 4 Service tank (right)

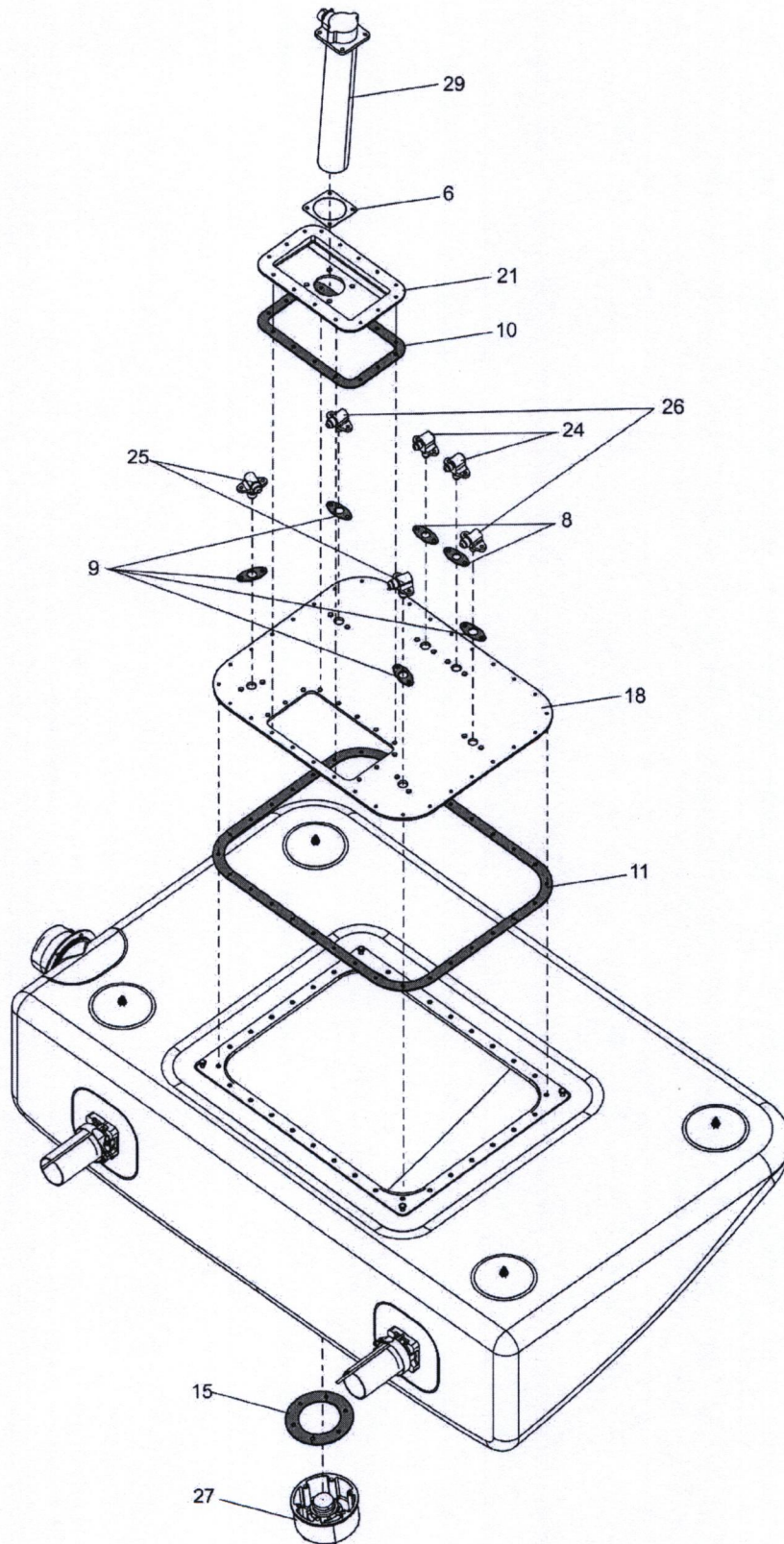

Fig. 5 Fuel tank No. 2

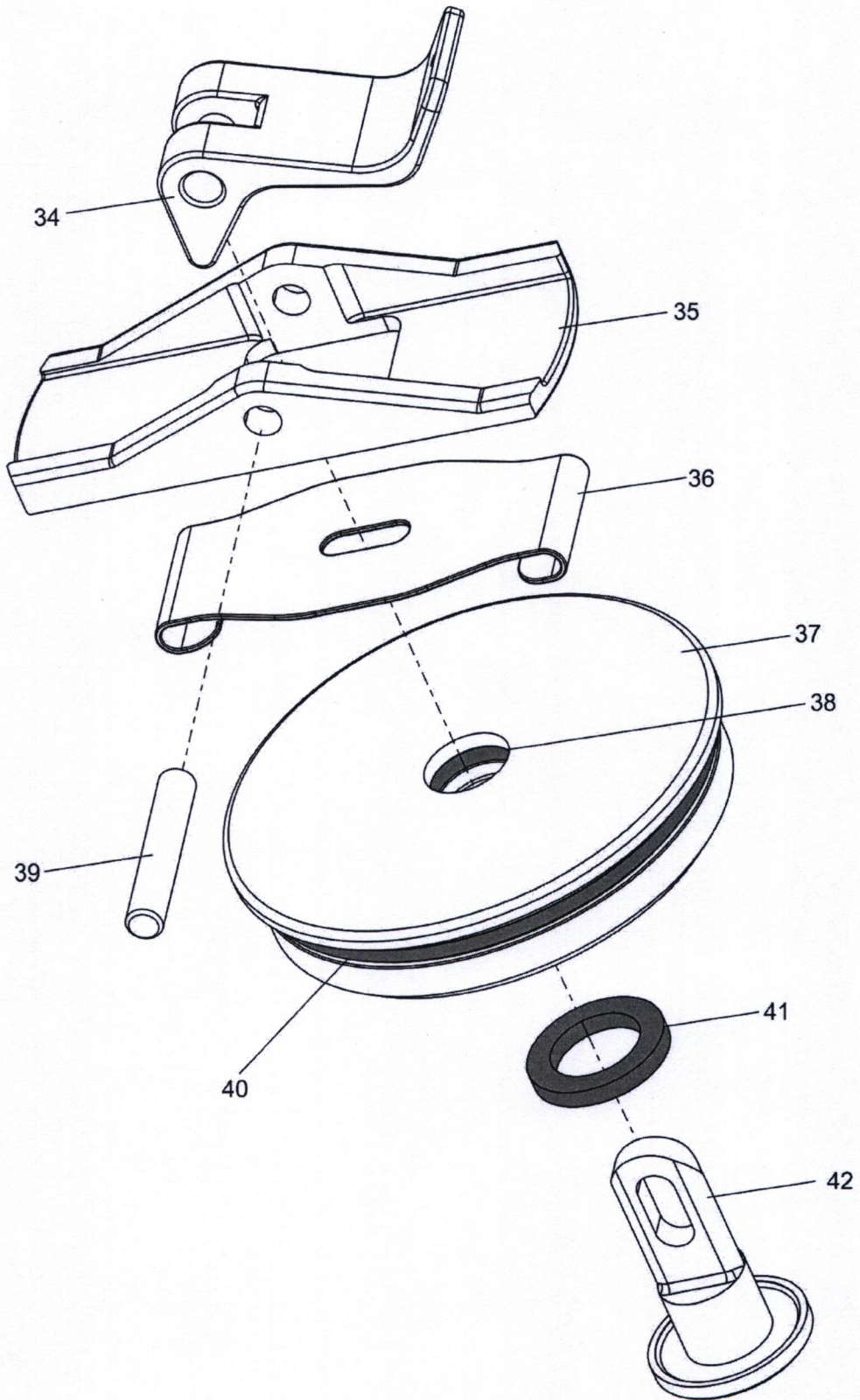

Fig. 6 Cover assembly

TECHNICAL DECISION No. 2/144-2023 –KB3
on continued airworthiness of ANSAT helicopters (ANSAT-GC model)

Table 1

Pos.	Quantity	Designation	Description
1	1	334.6110.210-05	Tank No. 1 assembly
2	1	334.6110.110-04	Service tank assembly (left)
3	1	334.6110.110-03	Service tank assembly (right)
4	1	334.6110.310-09	Tank No. 2 assembly
5	2	334.6110.660	Cover
6	4	333.6101.009	Gasket
7	2	334.6110.027	Gasket
8	4	334.6110.029	Gasket
9	13	334.6110.051	Gasket
10	1	334.6110.311	Gasket
11	2	334.6110.572	Gasket
12	2	334.6110.573	Gasket
13	2	334.6110.575	Gasket
14	2	334.6110.576	Gasket
15	2	334.6110.578	Gasket
16	2	334.6110.822	Gasket
17	1	334.6110.271	Plate of tank 1
18	1	334.6110.351	Plate of tank 2
19	1	334.6110.811-03	Plate of service tank
20	1	334.6110.811-04	Plate of service tank
21	1	334.6110.371	Cover
22	1	334.6110.821-02	Service tank plate cover
23	1	334.6110.821-01	Service tank plate cover
24	4	334.6110.016	Angle-piece
25	10	334.6110.009-05	Angle-piece
26	3	334.6110.015	Angle-piece
27	4	-	Tank sump
28	2	334.6110.007	Flange
29	4	-	Fuel level sensor
30	2	-	Fuel level switch
31	1	334.6110.030-07	Mounting device with pump
32	1	334.6110.030-05	Mounting device with pump
33	2	333.6101.008	Gasket
34	2	334.6110.664	Lever
35	2	334.6110.663	Retainer
36	2	334.6110.662	Spring
37	2	334.6110.666	Cover
38	2	012-015-19-2-034- OCT1 00980-80	Ring
39	2	334.6110.665	Axle
40	2	061-065-25-2-034- OCT1 00980-80 или 334.6130.024	Rubber ring
41	2	334.6110.668	Washer
42	2	334.6110.667	Axle

Temporary task card 028.10.00g

Procedure: Cleaning the fuel system	Corrective actions
Operations and technical requirements	
<p>1 Perform cleaning of fuel tanks Nos. 1 and 2 and service tanks from foreign objects using a cotton cloth.</p> <p>2 After removal of parts and components of fuel tanks installation, flush the pipelines and jet pumps with HEФPAC gasoline, then blow with compressed air. Flush fuel level sensors, fuel level switches and drain taps with HEФPAC gasoline.</p> <p>3 Remove the fuel level switches ДСУ5-3А, ДСУ5-3Б, ДСМК-10-15 (according to task card 028.40.00a of 343.0000.00 PЭ).</p> <p>4 Check the fuel level switches ДСУ5-3А and ДСУ5-3Б. To do this, hold the sensor vertically and turn it by 180°. In this case, the magnet must move inside the cylinder and there should be no jamming of it. Perform sensor serviceability test according to task card 028.40.00h of 343.0000.00PЭ.</p> <p>5 Check the level switches ДСМК-10-15. To do this, hold the sensor vertically and turn it by 180°. In this case, the magnet must move inside the cylinder and there should be no jamming of it. Perform visual inspection of level switches according to task card 028.40.00g of 343.0000.00 PЭ.</p> <p>6 Remove the electric centrifugal pumps ЭЦН-73 from mounting device in accordance with task card 028.20.00a of 343.0000.00 PЭ and blow the inner cavities with compressed air. Install the electric centrifugal pumps ЭЦН-73 into mounting device in accordance with task card 028.20.00b of 343.0000.00 PЭ. After assembly, check the electric centrifugal pumps ЭЦН-73 for serviceability at the premises of JSC “Kazan Helicopters”.</p> <p>7 Remove the following components from the helicopter portside, having disconnected the electrical connectors beforehand:</p> <ul style="list-style-type: none"> - T-piece 334.6100.010-05; - pressure switch MCTB-0,3C (pos. 8 figure 1 section 028.00.00 of 343.0000.00 PЭ); - electromagnetic valve MKT-16 (pos. 21 figure 1 section 028.00.00 of 343.0000.00 PЭ); - check valve 334.6100.020, having removed at that the valve 989AT-1-12; - cross-feeding line, having disconnected at that the electromagnetic valves 601200A and thermal valve 334.6100.200. <p>8 Remove the following components from the helicopter starboard, having disconnected the electrical connectors beforehand:</p> <ul style="list-style-type: none"> - T-piece 334.6100.310; - pressure switch MCTB-0,3C (pos. 8 figure 1 section 028.00.00 of 343.0000.00 PЭ); - electromagnetic valve MKT-16 (pos. 21 figure 1 section 028.00.00 of 343.0000.00 PЭ); 	<p>Replace sensor</p> <p>Replace sensor</p>

<p>- check valve 333.6100.020, having removed at that the valve 989AT-1-12;</p> <p>9 Remove T-pieces 334.6100.170 (pos. 17 figure 1 section 028.00.00 of 343.0000.00 PЭ), having disconnected at that the pressure sensors 3AB-526-00 (pos. 16 figure 1 section 028.00.00 of 343.0000.00 PЭ).</p> <p>10 After removal of fuel system components according to pp. 7 – 9, flush the pipelines with HEФPAC gasoline, then blow with compressed air. Flush the T-pieces 333.6100.020, 334.6100.020, 334.6100.170, thermal valve, check valves, cross-feed valves and electromagnetic valves with HEФPAC gasoline.</p> <p>CAUTION. FLUSH THE ELECTROMAGNETIC VALVE MKT-16 BY MEANS OF POURING THE HEФPAC GASOLINE INTO THE INLET FITTING.</p> <p>11 Blow the lines of fuel supply from electromagnetic valves to T-pieces 334.6100.170 with compressed air, at that supply air through fluoroplastic hoses (pos. 18 figure 1 section 028.00.00 of 343.0000.00 PЭ).</p> <p>12 Check the pressure switches MCTB-0,3C for the purpose of confirmation of the switch alarm point at the premises of JSC “Kazan Helicopters”.</p> <p>13 Install the following components: pressure sensor 3AB-526-00 in accordance with task card 028.40.00f of 343.0000.00 PЭ, pressure switch MCTB-0,3C in accordance with task card 028.40.00d, fuel level switches ДСУ5-3А, ДСУ5-3Б, ДСМК-10-15 in accordance with task card 028.40.00b of 343.0000.00 PЭ.</p> <p>Replace level switch</p>	<table border="1"> <thead> <tr> <th data-bbox="1145 1330 1217 2054">Test equipment</th> <th data-bbox="1145 607 1217 1330">Tools and appliances</th> <th data-bbox="1145 136 1217 607">Expendable materials</th> </tr> </thead> <tbody> <tr> <td data-bbox="1217 1330 1460 2054"></td> <td data-bbox="1217 607 1460 1330"> <p>Pliers L=160 mm Screwdriver 1.0x6.5x190 Portable lamp Wrenches S=10x12, 17x19 Hose for fuel drain 333.9901.000 Stepladder H=1400 mm (Stepladder 333.9917.100 (HАЛФ.333.9917.100)) High pressure compressor</p> </td> <td data-bbox="1217 136 1460 607"> <p>Cotton cloth HEФPAC gasoline</p> </td> </tr> </tbody> </table>	Test equipment	Tools and appliances	Expendable materials		<p>Pliers L=160 mm Screwdriver 1.0x6.5x190 Portable lamp Wrenches S=10x12, 17x19 Hose for fuel drain 333.9901.000 Stepladder H=1400 mm (Stepladder 333.9917.100 (HАЛФ.333.9917.100)) High pressure compressor</p>	<p>Cotton cloth HEФPAC gasoline</p>
Test equipment	Tools and appliances	Expendable materials					
	<p>Pliers L=160 mm Screwdriver 1.0x6.5x190 Portable lamp Wrenches S=10x12, 17x19 Hose for fuel drain 333.9901.000 Stepladder H=1400 mm (Stepladder 333.9917.100 (HАЛФ.333.9917.100)) High pressure compressor</p>	<p>Cotton cloth HEФPAC gasoline</p>					

Temporary task card 028.10.00h	
Procedure: Replacement of washer 334.6110.668 in cover assembly	
Operations and technical requirements	Corrective actions
<ol style="list-style-type: none"> 1 Remove the axle (pos. 4 figure 201) by knocking out and disassemble the cover assembly. 2 Perform visual inspection of rubber rings (pos. 8, 9 figure 201) without their removal from cover (pos. 5 figure 201). Mechanical damages or deformations of rubber rings are not allowed. 3 Replace rubber washer (pos. 7 figure 201) with a new one. 4 Assemble the cover assembly, the axle (pos. 4 figure 201) removed according to p. 1, install using glue BK-9 III1.2A.526-99. Ensure free and jam-free rotation of the lever relative to the axle. 	<p>Replace the ring</p>

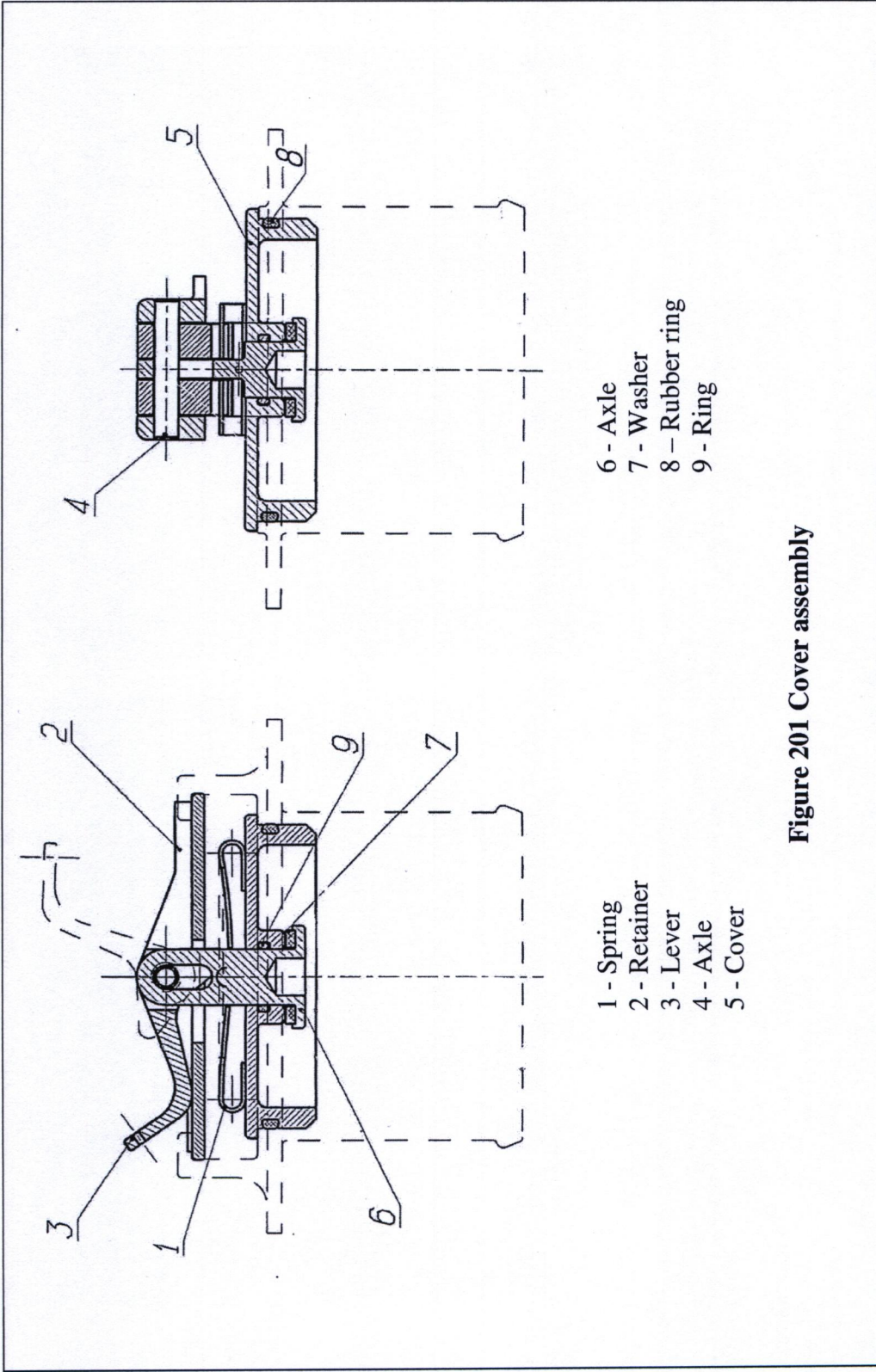

Figure 201 Cover assembly

Test equipment	Tools and appliances	Expendable materials
	Piercer Hammer	Cotton cloth, Glue BK-9, Washer 334.6110.668