



RUSSIAN FEDERATION
MINISTRY OF TRANSPORT OF RUSSIAN FEDERATION
FEDERAL AIR TRANSPORT AGENCY
AIRWORTHINESS DIRECTIVE

21 of October, 2021

No. 2021-AHCAT, AHCAT-K-04

Applicability – ANSAT, ANSAT-K helicopters (model ANSAT-K) and their modifications

Designer's State - RUSSIAN FEDERATION

Corrective actions stated in the present Airworthiness Directive are mandatory. None of the operators is allowed to operate the aircraft covered by present Airworthiness Directive otherwise than according to the requirements of present Directive.

In connection with the aviation accident occurred on 23.09.2021 with the ANSAT helicopter RA-20014 (serial No. 33090), which made a hard landing due to decrease in control margins in directional control channel, which resulted in uncontrolled left rotation of the helicopter during the approach, and detection of destruction of the bearing 6-3056204 ETY100/3 of the tail rotor sliding bar, as well as based on Technical Decision of JSC "Kazan Helicopters" No. 1/144-2021-KB3 Revision 2 dated 20.10.2021, in order to ensure airworthiness of the ANSAT, ANSAT-K helicopters and their modifications being in operation, at the stage of serial production or transfer to the operator, the following is

PROPOSED:

1. Operators of ANSAT, ANSAT-K helicopters and their modifications to suspend operation of ANSAT helicopters having serial Nos. 33072, 33073, 33077, 33088...33093 with bearings 6-3056204 ETY100/3 of the tail rotor sliding bar installed by JSC "Kazan Helicopters" in the course of helicopters manufacturing until their replacement in the course of operation.

2. Based on Conclusion of Chief designer of Design Bureau of JSC "Kazan Helicopters" No. АНС-ПР-3ЧУРВ-2021-1 dated 20.10.2021 to allow installation of the bearing 6-3056204Y ETY100/3 instead of bearing 6-3056204 ETY100/3 (Appendix 3 of Technical Decision No. 1/144-2021-KB3 dated 20.10.2021).

3. To perform works in accordance with the pp. 1.2-1.4, 6, 7, 7.1 of Technical Decision of JSC "Kazan Helicopters" No. 1/144-2021-KB3 dated 20.10.2021 on the entire fleet of ANSAT, ANSAT-K helicopters and their modifications from the moment of the issue of present airworthiness directive.

4. To establish service life limitation of 300 f. h. for tail rotor sliding bar bearings 6-3056204 ETY100/3, having total operating time less than 300 f. h. at the moment of issue of present airworthiness directive. To establish service life limitation of 100 f. h. over the total operating time for tail rotor sliding bar bearings 6-3056204 ETY100/3, having total operating time of 300 f. h. and more at the moment of issue of present airworthiness directive.

To establish service life / service time for newly installed bearings 6-3056204 ETY100/3 (6-3056204Y ETY100/3) – 300 f. h. / 8 years.

5. To establish the frequency of works on the replacement of grease of bearing 6-3056204 ETY100/3 (6-3056204Y ETY100/3) according to task card No. 064.10.00g of Maintenance manual 338.0000.00PЭ (for ANSAT helicopter), according to task card No. 065.20.00л of Maintenance manual 340.0000.00PЭ (for ANSAT-K helicopter) – every 50±5 f. h.

6. To establish the frequency of checking the axial play of the bearing 6-3056204 ETY100/3 (6-3056204Y ETY100/3) according to task card No. 064.20.00f of Maintenance manual 338.0000.00PЭ (for ANSAT helicopter), according to task card No. 065.20.00м of Maintenance manual 340.0000.00PЭ (for ANSAT-K helicopter) – every 50±5 f. h. Limitation for value of axial play of bearing 6-3056204 ETY100/3 – no more than 0.014 mm, for bearing 6-3056204Y ETY100/3 - no more than 0.035 mm.

7. To establish the frequency of works on the replacement of grease of bearings 6-2007105A of ANSAT helicopter tail rotor common flapping hinge according to task card No. 064.20.00k of Maintenance manuals 338.0000.00PЭ for ANSAT helicopter – every 50±5 f.h.

8. Airworthiness directive comes into force from the date of its issue. Operators shall follow the requirements of paragraphs of present airworthiness directive until the issue of service bulletin A0465-БЭ-Г by JSC "Kazan Helicopters" or issue of another airworthiness directive on this aviation accident.

Appendix: Technical decision No. 1/144-2021-KB3 Revision 2 dated 20.10.2021, 15 sheets.

Deputy Director General

П.П.

A.A. Novgorodov

Верно:



И.В. Пономарев

УПДГ ВС

И.В. Пономарев

APPROVED BY
Deputy managing director –
Head of design
JSC “Kazan Helicopters”,
A.O. Garipov

TECHNICAL DECISION No. 1/144-2021-KB3
on continued airworthiness of ANSAT, ANSAT-K (ANSAT-K model) helicopters and their
modifications in connection with failure of the bearing 6-3056204 ETY100/3 of tail rotor
sliding bar
Revision 2

In connection with the aviation accident occurred on 09/23/2021 with the ANSAT helicopter No. 33090 (RA-20014), which made a hard landing, inspection of the helicopter was carried out and destruction of the bearing 6-3056204 ETY100/3 of the tail rotor sliding bar was detected. This destruction resulted in decrease in control margins and uncontrolled left rotation of the helicopter during landing.

In order to ensure the airworthiness of the ANSAT, ANSAT-K helicopters and their modifications, which are in operation and at the stage of serial production at JSC “Kazan Helicopters”, the following decision was made.

DECISION:

1. On the entire fleet of ANSAT helicopters, ANSAT-K helicopters and their modifications (from the moment of issue of the airworthiness directive):

1.1 Remove from operation the bearings 6-3056204 ETY100/3 of tail rotor sliding bar installed on the ANSAT helicopters having serial numbers 33072, 33073, 33077, 33088...33093 by the ANSAT helicopters manufacturer JSC “Kazan Helicopters” in the course of their manufacturing (if the bearings were not replaced on the mentioned helicopters in the course of operation).

1.2 Perform works according to task cards Nos. 022.52.00f, 064.10.00c, 064.20.00a, 064.20.00b, 065.10.00a, 065.20.00a, 067.20.00a, 067.20.00e, 067.20.00h of Maintenance manuals 338.0000.00PЭ (for ANSAT helicopter), according to task cards Nos. 065.20.00a, 065.20.00б, 065.20.00ж, 065.40.00e, 084.30.00a, 084.40.00a of Maintenance manual 340.0000.00PЭ (for ANSAT-K helicopter).

1.3 Perform operations and inspections of the tail rotor elements in accordance with the temporary task card No. 064.20.00м (Appendix 1). List of parts and assemblies of tail rotor hub is given in Appendix 2.

1.4 Inform JSC “Kazan Helicopters” and FATA about the results of works performed under paragraphs 1.1-1.3.

When performing the works per paragraphs 1.2-1.3, it is allowed to consider the works, earlier performed according to the letter of JSC “Kazan Helicopters” No. 32426-144 dated 01.10.2021, as completed.

2. Upon completion of works per paragraphs 1.2-1.3 of present technical decision and in the absence of any remarks:

TECHNICAL DECISION No. 1/144-2021-KB3

on continued airworthiness of ANSAT, ANSAT-K (ANSAT-K model) helicopters and their modifications in connection with failure of the bearing of tail rotor sliding bar

Revision 2

– for tail rotor sliding bar bearings 6-3056204 ETY100/3, having total operating time less than 300 f. h. at the moment of issue of airworthiness directive, establish service life limitation of 300 f. h.;

- for tail rotor sliding bar bearings 6-3056204 ETY100/3, having total operating time of 300 f. h. and more at the moment of issue of airworthiness directive, establish service life limitation of 100 f. h. over the total operating time.

3. Allow the installation of bearing 6-3056204Y ETY100/3 instead of bearing 6-3056204 ETY100/3 (basis – Conclusion No. АНС-ПР-3ЧУРВ-2021-1, Appendix 3).

Service life / service time for newly installed bearings 6-3056204 ETY100/3 (6-3056204Y ETY100/3) – 300 f. h. / 8 years.

4. Establish the frequency of works on the replacement of grease of bearing 6-3056204 ETY100/3 (6-3056204Y ETY100/3) according to task card No. 064.10.00g of Maintenance manuals 338.0000.00PЭ (for ANSAT helicopter), according to task card No. 065.20.00л of Maintenance manual 340.0000.00PЭ (for ANSAT-K helicopter) – every 50±5 f. h.

5. Establish the frequency of checking the axial play of the bearing 6-3056204 ETY100/3 (6-3056204Y ETY100/3) according to task card No. 064.20.00f of Maintenance manuals 338.0000.00PЭ (for ANSAT helicopter), according to task card No. 065.20.00м of Maintenance manual 340.0000.00PЭ (for ANSAT-K helicopter) – every 50±5 f. h.

Limitation for value of axial play of bearing 6-3056204 ETY100/3 – no more than 0.014 mm, for bearing 6-3056204Y ETY100/3 - no more than 0.035 mm.

6. Perform works on replacement of bearing 6-3056204 ETY100/3 (6-3056204Y ETY100/3) according to task cards Nos. 064.20.00c, 064.20.00d of Maintenance manuals 338.0000.00PЭ (for ANSAT helicopter), according to task cards Nos. 065.20.00в, 065.20.00r of Maintenance manual 340.0000.00PЭ (for ANSAT-K helicopter).

Before installation wash the bearing in HEФРАС solvent and check for smooth rotation without jamming. It is not allowed to install the bearing in case jamming was detected.

After replacement of bearing 6-3056204 ETY100/3 (6-3056204Y ETY100/3) check adjustment of tail rotor control system in accordance with the task card No. 067.20.00f of Maintenance manuals 338.0000.00PЭ (for ANSAT helicopter), in accordance with the task card 065.40.00и of Maintenance manual 340.0000.00PЭ (for ANSAT-K helicopter).

It is prohibited to reinstall the bearing 6-3056204 ETY100/3 (6-3056204Y ETY100/3) from tail rotor sliding bar of one helicopter to tail rotor sliding bar of another helicopter.

7. Record of replacements and total operating time of bearing 6-3056204 ETY100/3 and 6-3056204Y ETY100/3 shall be kept in the certificate 333.3520.1000-ПЦ of tail rotor sliding bar in section “7.2. Running repair and works performed according to service bulletins and instructions”.

7.1 Make changes in the certificate 333.3520.1000-ПЦ of tail rotor sliding bar according to the Annex 4.

At that make an entry in column “Remarks” in section 2 “Delivery set” of certificate 333.3520.1000-ПЦ of the number of actually installed washer 333.3500.0033- and 333.3500.0037- (see Annex 5), having measured their thicknesses beforehand.

TECHNICAL DECISION No. 1/144-2021-KB3

on continued airworthiness of ANSAT, ANSAT-K (ANSAT-K model) helicopters and their modifications in connection with failure of the bearing of tail rotor sliding bar

Revision 2

8. Establish the frequency of works on the replacement of grease of bearings 6-2007105A of ANSAT helicopter tail rotor common flapping hinge according to task card No. 064.20.00k of Maintenance manuals 338.0000.00PЭ for ANSAT helicopter – every 50 ± 5 f.h.

9. The present technical decision also applies to ANSAT, ANSAT-K helicopters and their modifications, which are at the stage of final assembly, painting, acceptance testing and tests, as well as transfer to Customer at JSC “Kazan Helicopters”.

10. Operators shall follow the requirements of the paragraphs of this technical decision until the issue of service bulletin A0465-БЭ-Г by JSC “Kazan Helicopters” or issue of another airworthiness directive.

TECHNICAL DECISION No. 1/144-2021-KB3
on continued airworthiness of ANSAT, ANSAT-K (ANSAT-K model) helicopters
and their modifications in connection with failure of the bearing of tail rotor sliding bar
Revision 2

APPENDIX 1

Temporary task card 064.20.00 м	
Procedure: Inspection of tail rotor elements	
Operations and technical requirements	Corrective actions
<ol style="list-style-type: none"> 1. Remove sliding bar from tail gearbox shaft: <ol style="list-style-type: none"> 1.1 Place a step-ladder near the tail gearbox. 1.2 Connect a ground hydraulic unit to the helicopter hydraulic system. Switch on the power supply. Set the sliding bar to a maximum extended position, having fully pressed the left pedal in the pilot's cabin as far as it can go. 1.3 Unlock and undo the nuts from the bolts attaching tie-rods to the rocker, remove the bolts. Disconnect tie-rods from the rocker. 1.4 Unlock and undo the nuts of the blades scissors pins. Remove washers of hubs and tie-rods from the pins. 1.5 Unlock the nut retaining the outer ring of the sliding bar bearing. 1.6 Install fixture 333.9950.000 (НАЛФ.333.9950.000) on the rocker and undo the nut. Remove the washer and cover installed in the sliding bar. 1.7 Unlock the rod nut, having unbent lobes of the flap locks. Undo the nut. Remove the stop washer from the rod.. 1.8 Having moved the sliding bar with a rocker towards the tail rotor, remove the bearing from the sliding bar. Remove the bearing and the bushing, installed under the bearing, from the rod. 2. Check the bearing (pos. 29, fig. 1 of this card) with the bushing (pos. 30) installed in it for absence of seizing, jamming, non-smooth running, extraneous noise. In case of detection of these defects, the bearing and bushing shall be replaced. 3. Remove bushing (pos. 30) from inner ring of the bearing (pos. 29). If it is impossible to remove the bushing by hand force - the bushing and the bearing must be replaced. <p>CAUTION: THE BUSHING MUST BE REMOVED FROM THE BEARING WITHOUT TENSION, BY HAND FORCE. THERE SHOULD BE NO MECHANICAL DAMAGES ON THE BEARING (INCLUDING VISIBLE PARTS OF THE SEPARATOR) (SCRATCHES, NICKS). THE BEARING SHOULD ROTATE SMOOTHLY, WITHOUT JAMMING.</p> <ol style="list-style-type: none"> 4. Install the sliding bar on the tail gearbox shaft: 	

4.1 Install the bushing on the rod.

Install the bearing on the bushing, having first flushed it from the old grease and applied fresh ЦИАТИМ-201 grease on it.

CAUTION: THE BEARING MUST BE INSTALLED ON THE BUSHING WITHOUT TENSION, BY HAND FORCE. THERE SHOULD BE NO MECHANICAL DAMAGES ON THE BEARING (INCLUDING VISIBLE PARTS OF THE SEPARATOR) (SCRATCHES, NICKS). THE BEARING SHOULD ROTATE SMOOTHLY, WITHOUT JAMMING.

The bearing should be installed in such a way that the bearing marking is facing in the direction opposite to the tail rotor.

4.2 Install the retaining washer on the rod.

Install new flap locks on the rod grooves.

4.3 Screw on the rod nut on the rod and lock it with 18...20 N•m (1.8...2.0 kgf•m) torque, by aligning grooves on the rod with nut slots.

4.4 Lock the rod nut, having bent lobes of the flap locks into the nut slots.

4.5 Slide the sliding bar from the tail rotor, having put the sliding bar bearing, secured on the rod, into the sliding bar.

4.6 Install the cover and washer. Return the nut into the sliding bar and tighten it with 60...70 N•m (6.0...7.0 kgf•m) torque using fixture 333.9950.000 (НАЛФ.333.9950.000) preinstalled on the rocker. When tightening the nuts, align the nut slots with holes in the sliding bar.

4.7 Lock the nut using two locking screws, installed in the holes of the sliding bar, aligned with the grooves of the nut (pos. 35) and screw them into the nuts (pos. 45). Lock the screws with locking wire 0.8mm in diameter wire.

TECHNICAL DECISION No. 1/144-2021-KB3

on continued airworthiness of ANSAT, ANSAT-K (ANSAT-K model) helicopters and their modifications in connection with failure of the bearing of tail rotor sliding bar
Revision 2

<p>4.8 Install rods on the blades scissors when installing distance bushings and dust-reflecting washers. Install lock washers, screw on nuts on the scissors pins, tighten up nuts with 18...20 N•m (1.8...2.0 kgf•m). Lock the nut with 2.5x25 cotter pins and 0.8 mm diameter locking wire.</p> <p>4.9 Install tie-rods on the rocker.</p> <p>During installation, check availability of distance bushings between the rocker lugs and bearing of the tie-rod.</p> <p>4.10 Lock the nut of the tie-rod attachment bolt with 18...20 N•m (1.8...2.0 kgf•m) torque.</p> <p>4.11 Lock the nut with 2.5x25 cotter pins and, by unbending the locking washer tabs on the nut edge, install 2x32 cotter pin into the rocker from the bolt head side.</p> <p>5. Check tail rotor setting angle in accordance with task card No. 67.20.00d (for ANSAT helicopters), TC 65.40.00и (for ANSAT-K helicopters).</p>	
--	--

on continued airworthiness of ANSAT, ANSAT-K (ANSAT-K model) helicopters and their modifications in connection with failure of the bearing of tail rotor sliding bar
Revision 2

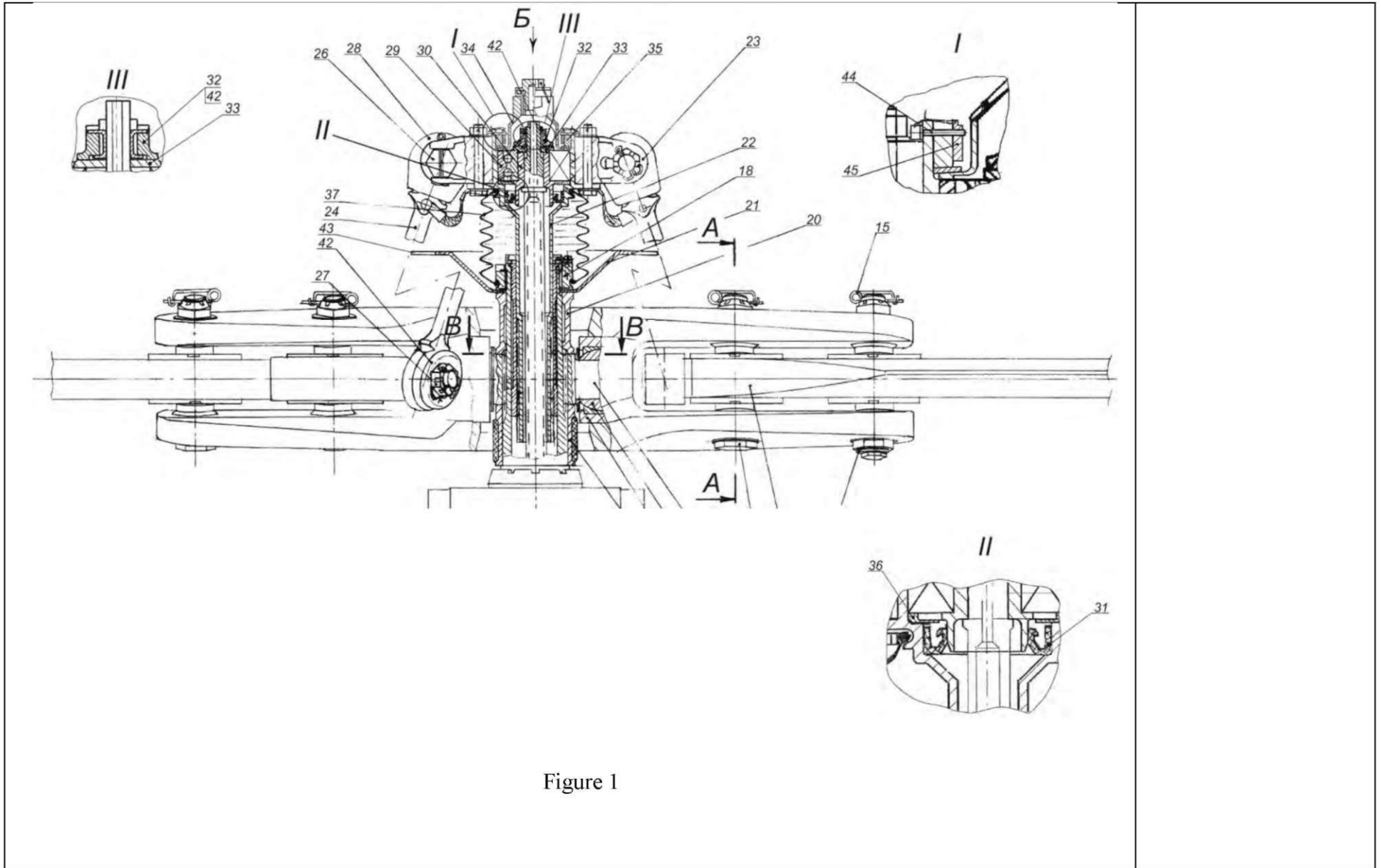

Figure 1

TECHNICAL DECISION No. 1/144-2021-KB3

on continued airworthiness of ANSAT, ANSAT-K (ANSAT-K model) helicopters and their modifications in connection with failure of the bearing of tail rotor sliding bar
Revision 2

Test equipment	Tools and appliances	Expendable materials
Ground hydraulic unit	Combination pliers L=160 mm Wrenches S=19x22, S=10x11, S=12x14; S=17x19 Calibrated wrench Screwdriver 1.6x10x275 Device for tightening the sliding bar bearing nut 333.9950.000 (НАЛФ.333.9950.000) Attachment piece ЧА.9100.250 for the tail rotor hub nut (НАЛФ.ЧА.9100.250) Bushing ЧА.9100.202 (НАЛФ.ЧА.9100.202) Wrench interchangeable tool S=17 mm End attachment piece S=14 mm Changeable ratchet for 1/4" Tail beam support 333.9900.100 (НАЛФ.333.9900.100) Stepladder H=1400 mm (stepladder 333.9917.100 (НАЛФ.333.9917.100)) Torque wrench up to 100 N·m	Cotton cloth НЕФРАС solvent Grease СТ (НК-50) Grease ЦИАТИМ-201 Oil Б-3В Cotter pins 3,2x40 per ГОСТ 397-79 standard Cotter pin 2,5x25.0.02 per ГОСТ 397-79 standard Cotter pins 2x32 per ГОСТ 397-79 standard Wire КС 0,8 Flap locks 333.3500.0032-03

on continued airworthiness of ANSAT, ANSAT-K (ANSAT-K model) helicopters and their modifications in connection with failure of the bearing of tail rotor sliding bar
 sliding bar
 Revision 2

List of parts and assemblies of tail rotor hub

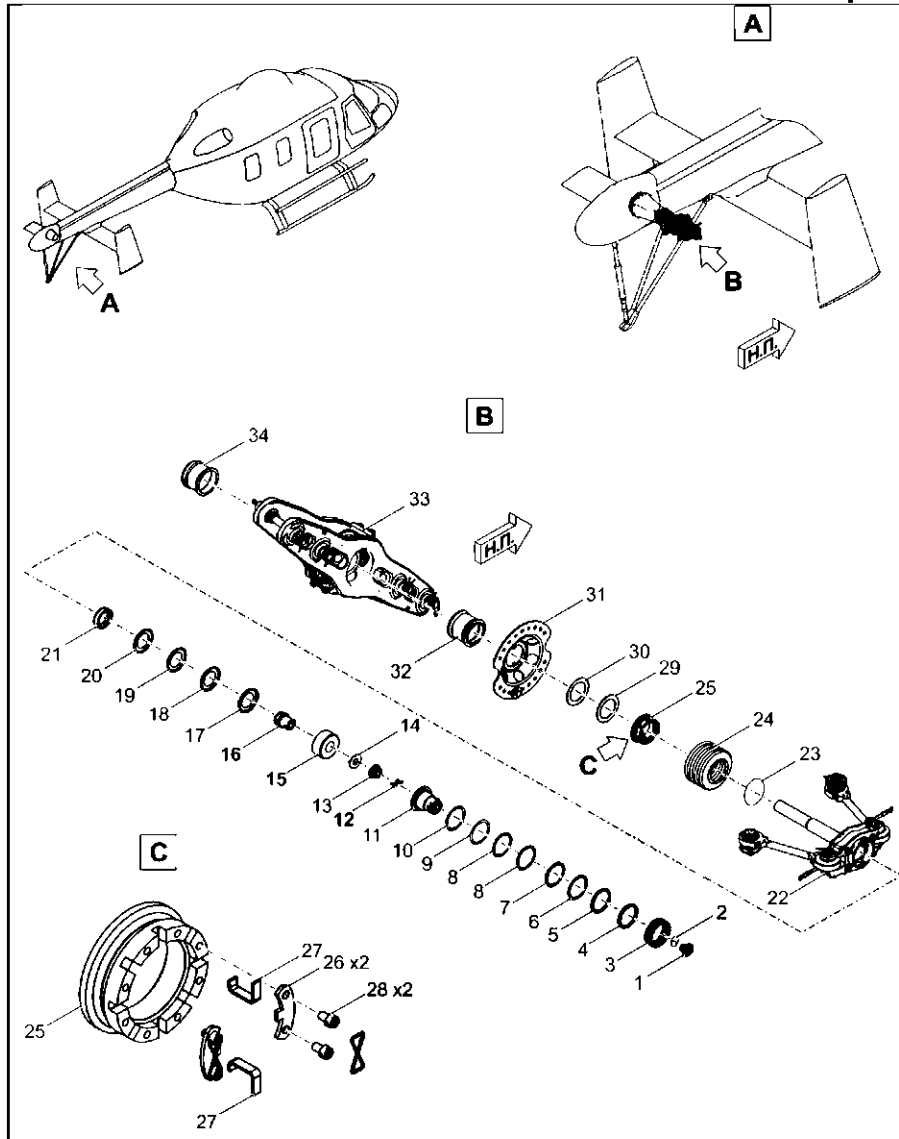

Pos.	Qty	Designation	Description
1	1	333.3500.0014	Plug
2	1	017-020-19-2-043 OCT1.00980-80	Ring
3	1	331.3500.0018	Nut
4	1	333.3500.0033-11	Washer
5	1	333.3500.0033-05	Washer
6	1	333.3500.0033-07	Washer
7	1	333.3500.0033-09	Washer
8	2	333.3500.0033-03	Washer
9	1	333.3500.0033-13	Washer
10	1	333.3500.0033-15	Washer
11	1	333.3500.0041	Cover
12	2	333.3500.0032-05	Lock
13	1	333.3500.0017	Nut
14	1	333.3500.0022	Locking washer
15	1	6-3056204 ETY100/3	Bearing
16	1	333.3500.0015	Sleeve
17	1	333.3500.0037-09	Washer
18	1	333.3500.0037-07	Washer
19	1	333.3500.0037-05	Washer
20	1	333.3500.0037-03	Washer
21	1	333.3500.0020	Washer
22	1	333.3520.1000-05	Sliding bar in assembly
23	1	023-026-19-1-061-OCT1.00980-80	Ring
24	1	333.3500.0004	Cover
25	1	333.3500.0005	Nut
26	2	333.3500.0006	Retainer
27	2	333.3500.0032-03	Lock
28	4	3-5КД-OCT1.31522-80	Screw
29	1	333.3500.0031-05	Washer
30	1	333.3500.0031-03	Washer
31	1	333.3500.0012	Disc
32	1	333.3500.0003	Spacer sleeve
33	1	333.3530.2000	Tail rotor hub
34	1	333.3500.0010	Spacer sleeve

APPROVED BY
Deputy managing director –
Head of design
JSC “Kazan Helicopters”,
A.O. Garipov

CONCLUSION No. AHC-ИП-34УРВ-2021-1
about the possibility of installation of bearing 6-3056204Y ETY100/3
instead of bearing 6-3056204 ETY100/3 of the actuating portion of tail rotor control system
of ANSAT, ANSAT-K helicopters and their modifications

This Conclusion is based on the following documents:

1. ANSAT helicopter Certification basis СБ АНКАТ.29-2013 Issue 2;
2. Conclusion No. АНКАТ-С3-Пр-2016-1 on the compliance of static strength of the ANSAT helicopter type design with the requirements of Certification basis СБ АНКАТ.29-2013. Type design major change "Maximum takeoff weight 3600 kg", 2016;
3. Conclusion No. АНКАТ-С3-29.571-2016-1 on the compliance of the ANSAT helicopter type design with the requirements of p. 29.571 of Certification basis СБ АНКАТ.29-2013. Type design major change "Maximum takeoff weight 3600 kg", 2016;
4. Letter of LLC "ТД ЕПК" ref. No. 906/83/8735 dated 26.08.2021.
5. Report No. 1711 ИЛ ПНК ЛА of Kazan State Technical University named after A. N. Tupolev "Wear tests of three bearings 6-3056204У of the tail rotor rod of the ANSAT helicopter", 2003.

Based on the analysis of the listed materials, the following has been established.

1. Strength of bearing 6-3056204 ЕТУ100/3 of the actuating portion of tail rotor control system of the ANSAT helicopter is analyzed in accordance with the Certification basis [1] and established on the basis of conclusions on static [2] and fatigue [3] strength.
2. Based on letter [4] the identity of the design of bearings 6-3056204 ЕТУ100/3 and 6-3056204У ЕТУ100/3 is shown, with the exception of the axial clearance value:
 - bearing 6-3056204 ЕТУ100/3 has an axial clearance up to 0.01 mm;
 - bearing 6-3056204У ЕТУ100/3 has an axial clearance of 0.015...0.030 mm.
3. Changing the value of the operating axial clearance does not affect the static and fatigue strength of the bearing.
4. Based on the test results [5] and the methodology of assessment of the permissible safe interval for evaluation of the technical condition by measuring the axial play used in drawing up the conclusion [3], the permissible interval for assessing the technical condition by measuring the axial play in operation of bearing 6-3056204У ЕТУ100/3 is at least 283 hours with allowable total operating time of 1132 hours.

Tests were carried out with the use of grease ЦИАТИМ-201.

5. The increase in axial play during the tests [5] was $0.014 - 0.006 = 0.008$ mm. Therefore, the justified limit value of play of the bearing 6-3056204У ЕТУ100/3 should be considered as the following value:

$$0.030 + 0.008 = 0.038 \text{ mm.}$$

6. The provisions of this conclusion, due to the identity of design of the actuating portion of tail rotor control system and operating conditions, can be extended to the ANSAT-K helicopter and its modifications.

7 Conclusions

7.1 Based on the analysis of the design, it is allowed to install the bearing 6-3056204Y ETY100/3 instead of bearing 6-3056204 ETY100/3 in the actuating portion of tail rotor control system of ANSAT, ANSAT-K helicopters and their modifications.

7.2 Based on the materials provided in this conclusion, establish airworthiness limitation for bearing 6-3056204Y ETY100/3 in the amount of 300 f. h./8 years.

7.3 Establish the interval of assessment of technical condition by measuring the axial play of bearing 6-3056204Y ETY100/3 equal to 50 ± 5 f. h. Permissible value of the axial play should not exceed 0.035 mm.

7.4 Establish the interval of grease replacement in the bearing 6-3056204Y ETY100/3 equal to 50 ± 5 f. h.

TECHNICAL DECISION No. 1/144-2021-KB3
on continued airworthiness of ANSAT, ANSAT-K (ANSAT-K model) helicopters and their modifications in
connection with failure of the bearing of tail rotor sliding bar
Revision 2

ANNEX 4

Revision of delivery set
333.3520.1000-ПС

Introduce the following text in section “2. DELIVERY SET”:

Kit of mounting parts:

1. Nut	331.3500.0018	1
2. Cover	333.3500.0004	1
3. Nut	333.3500.0008	2
4. Plug	333.3500.0014	1
5. Sleeve	333.3500.0015	1
6. Nut	333.3500.0017	1
7. Collar	333.3500.0020	1
8. Locking washer	333.3500.0022	1
9. Bushing	333.3500.0026	2
10. Bushing	333.3500.0027	2

Add sheet “Sheet 4”:

Continued				
Description	Designation	Qty	Number	Remarks
1	2	3	4	5
11. Nut	333.3500.0028	2		
12. Washer	333.3500.0029	2		
13. Lock	333.3500.0032-05	2		
14. Washer	333.3500.0033-03	1*		
15. Washer	333.3500.0033-05	1*		
16. Washer	333.3500.0033-07	1*		
17. Washer	333.3500.0033-09	1*		
18. Washer	333.3500.0033-11	1*		
19. Washer	333.3500.0033-13	1*		
20. Washer	333.3500.0033-15	1*		
21. Washer	333.3500.0036	2		
22. Washer	333.3500.0037-03	1**		
23. Washer	333.3500.0037-05	1**		
24. Washer	333.3500.0037-07	1**		
25. Washer	333.3500.0037-09	1**		
26. Cover	333.3500.0040	1		

TECHNICAL DECISION No. 1/144-2021-KB3
on continued airworthiness of ANSAT, ANSAT-K (ANSAT-K model) helicopters and their modifications in
connection with failure of the bearing of tail rotor sliding bar
Revision 2

Add sheet “Sheet 5”:

				Continued
Description	Designation	Qty	Number	Remarks
1	2	3	4	5
27. Bearing	6-3056204 ETY 100/3	1		
28. Ring	017-020-19-2-043 OCT 1 00980-80	1		
29. Screw	3-10 КД OCT 1 31522-	2		
30. Washer	0.5-3-6КД OCT 1 34507-80	2		
31. Wire	КС-0,8 ГОСТ 792- 67	L= 0,8		
32. Cotter pin	2,5x25.0.026 ГОСТ 397-79	2		

*The mounting parts are selected by the contractor, when installing the sliding bar on the helicopter.

** The mounting parts are selected by the contractor, when adjusting the tail rotor control system.

Change the numbering of subsequent pages in the certificate.

Make an entry in section “8. Storage and operation notes”:

“Using the kit of mounting parts from another sliding bar assembly is not allowed.”

TECHNICAL DECISION No. 1/144-2021-KB3

on continued airworthiness of ANSAT, ANSAT-K (ANSAT-K model) helicopters and their modifications in connection with failure of the bearing of tail rotor sliding bar

Revision 2

ANNEX 5

